

TECHNICAL DATASHEET

RESOLTECH WWA Range

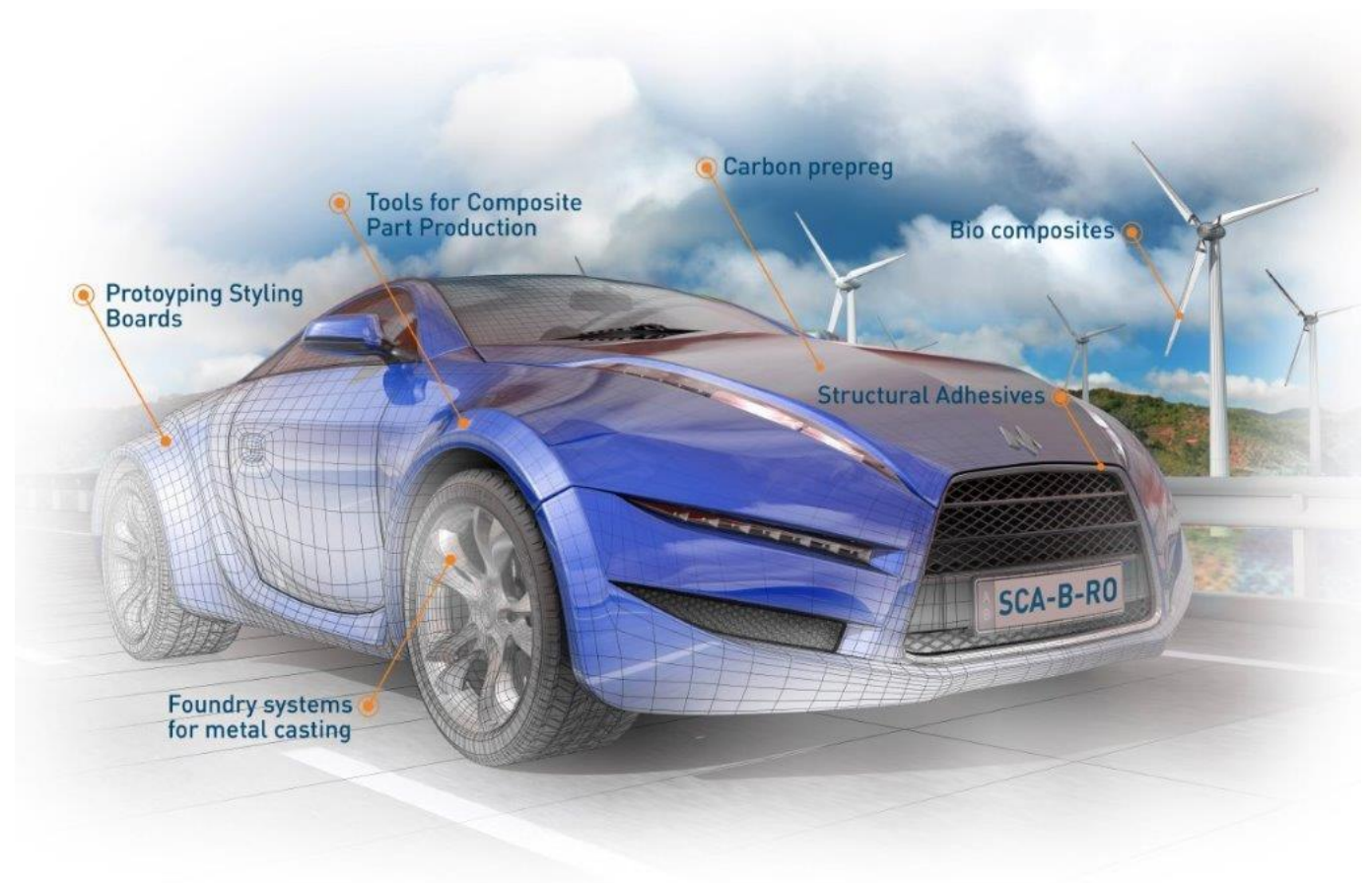

MALLENBOUW | COMPOSITEN | LIJMEN

WWA Range

Clear casting epoxy systems



- Perfectly clear and colorless
- Wide choice of reactivity & temperature resistances
- Excellent degassing properties
- Unmatched UV resistance (new formulas 2017)
- Very low viscosity
- Casting up to 16cm in one time

INTRODUCTION

The WWA range is clear casting epoxy system intended mainly for **decorative applications** but also for scientific instruments. Typical objects produced with the WWA include river tables, jewels, watches or any other casing with or without inclusions.

Totally colorless and clear, the system is **compatible with many substrates** such as glass, wood, concrete, stone, terracotta, metals...etc.

With its new formulation (October 2017), the WWA range offers **outstanding UV resistance**, unmatched on the market. Thanks to this major improvement, the manufacture of parts intended for outdoor use is now possible and it enables artist to produce long lasting objects with no yellowing in time.

All WWA resins can be coloured with epoxy compatible **pigments or tinting dyes**. Many **fillers** can also be added to the resins (metallic, nacre powder...).

Resoltech's **OPTICAL BRIGHTNER** additive (sold separately) will provide a slightly and unique blue color to the parts when exposed under UV light.

RESOLTECH has always been concerned by the user's health and safety and all the WWA systems are **solvents free and CMR components free**.

For castings in glass recipients, a **flexible version** is also available, please see page 4.

CHOOSING YOUR SYSTEM

1 Understanding exothermic reactions and mass effect

Epoxy resins are thermosetting resin, which means they release energy under the form of heat during hardening.

The thicker the quantity of resin you cast, the more heat is produced, and this is the mass effect.

All RESOLTECH WWA resins are recommended with a maximum casting thickness (see page 4), beyond this thickness, the heat generated cannot escape out of the resin fast enough and high reaction temperatures may result in yellowing, cracks and shrinkage (= exothermic reaction).

In order to choose the right system, please see below some examples of volumes. The orange arrows show the most constraining dimension for heat to escape.

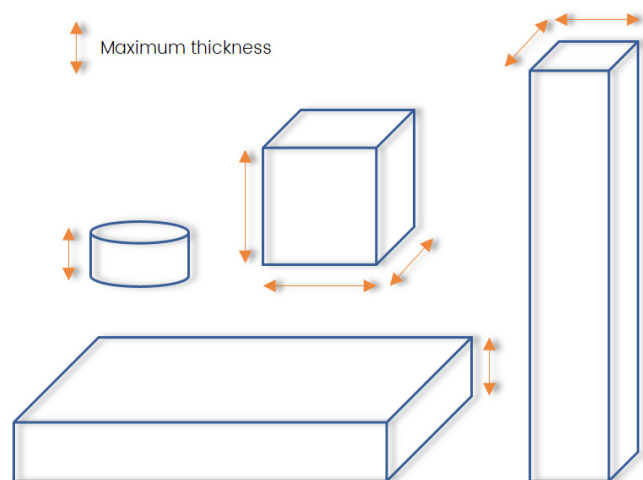

However, thickness is not the only constraining parameter, the quantity cast also influences the exotherm temperature as well as the mold material. See next page.

What influences the exotherm?

- **Resin/hardener system** : Within the WWA range, some systems are faster than others. Faster curing systems enable faster production, but will always also have a higher exotherm temperature, limiting the thickness they can be used on. Consequently, choosing the system adapted to part dimensions must be a primary consideration.
- **Resin/hardener temperature** : Storage temperature greatly influences the exotherm temperature. The hotter the initial temperature of the product, the higher the exotherm. Yet, storing and using product at lower temperature than 20°C is not recommended as a low temperature makes the viscosity of the resin increase and will affect the natural degassing properties of the resin.
- **Room temperature** : As for storing temperature, room temperature at which the resin is to be used has a major influence on the exothermic peak. WWA resins should not be casted when the room temperature is above 23°C when casting very thick quantities. On the contrary, a lower room temperature will reduce the exotherm and therefore will enable to cast bigger thicknesses. This is particularly important to take in account in summer where it may be necessary to cast in air-conditioned rooms only.

In summary: if you plan to cast very large art objects for example, the best is either to do it in winter when the temperature will naturally be low in your workshop (you just need to make sure you stored the resin above 20°C before mixing it) – or to make sure you have an air conditioned room.

- **Mould materials** : The materials used to build the moulds can be heat insulative or heat conductive. An insulative mold (made of wood or foam) will not help the resin dissipate calories generated by the reaction and thus will increase the exotherm temperature. On the contrary, a metal mold will improve heat diffusion and lower the exotherm temperature.

2 Heat Resistance

Heat resistances of WWA resins are given as T_g , it is the glass transition temperature. Above this temperature, the mechanical properties start to decrease – the resin will become more flexible. This phenomenon though is totally reversible when the temperature decreases.

Depending on the use and the forces applied to the manufactured part, the choice of the WWA system is important.

However, choosing a T_g above the maximum use temperature is not always necessary.

For example a thick coating on table top does not need a high T_g , on the contrary if the table top is totally made of resin then a T_g of 45°C is recommended.

Bear in mind and , high T_g (over 50°C) will only be obtained with a post curing.

*When has the resin reached its thermal resistance property?
Slow curing resins take also time to obtain their heat resistance (T_g). In case you need to speed up this curing process, postcuring the resin once it has passed its gel and its “b stage” (meaning it is hard but still tacky) at 40°C overnight will enable to quickly raise the T_g .*

3 WWA systems overview

Resin	WWAS		WWA HT		WWA		WWI A	WWA DELUXE	
Hardener	WWB HT	WWB4	WWB HT	WWB4	WWB HT	WWB4	WWI B	WWB HT	WWB4
Maximum thickness at 23°C *	0.5cm	0.5cm	2cm	4cm	4cm	9cm	2cm	12cm	16cm
UV resistance	Good	Good	Good	Good	Good	Good	Excellent	Excellent	Excellent
Under vacuum **	no	no	yes	yes	no	no	no	no	no
Post curing needed ***	no	no	no	no	no	no	yes	no	no
T _g max	62.1°C	50.2°C	77.2°C	58.3°C	58.4°C	46.1°C	97.0°C	39.1°C	32.1°C
Typical uses	Castings of thin layers such as tabletop coating or small parts a few mm thick that need higher mould turnaround therefore a higher reactivity		Parts that will have a higher mechanical solicitation or that need better thermal properties such as sinks...		Large castings where low reactivity is key: river tables, desiccated flower arrangements (water imitation), small sculptures like the car models on the first page...		High end, parts with high scratch and UV resistance (jewels, watches...)	When high transparency is needed for parts that are really thick and need extra UV resistance. Normally used for parts thicker than 4 cm. High-end art pieces.	

T_g tested on Kinetech®, curing cycle :3h at 50°C then 3h at 100°C and 3h at 150°C.

* Tested in PP bucket, cylindrical shape and width above or equal to thickness.

** Vacuum compulsory to remove air bubbles from the mix.

*** Post curing needed to avoid brittle stage.

PHYSICAL PROPERTIES

Resin	WWAS		WWA HT		WWA		WWI A	WWA DELUXE	
Hardener	WWB HT	WWB4	WWB HT	WWB4	WWB HT	WWB4	WWI B	WWB HT	WWB4
Mixing ratio by weight (R/H)	100/30	100/40	100/35	100/45	100/30	100/40	100/20	100/25	100/35
Mix viscosity (mPa.s)	326	324	380	430	280	292	1100	272	315
Hardness Shore D	86	84	89	86	86	85	88	80	79
Mix density	1.06	1.05	1.05	1.04	1.05	1.06	1.01	1.11	1.10
Gel time on 4cm at 23°C	15min	58min	7h16min	18h52min	14h14min	24h	4h46min	>16h	33h

Viscosity : ISO 12058.2 ± 15% tolerance

Reactivity measurements realized on Trombotech® on 70ml mix in air

Hardness : ISO 868

* To be done

Flexible versions of WWA/WWB4 (to be used when casting in glass containers for example)

Mixing ratio (weight) WWA/WWB4	100/40	100/50	100/60	100/70	100/80	100/90
Hardness Shore D after 14 days at 23°C	85	82	78	67	43	21
Hardness Shore D after 8h at 40°C	86	84	83	75	55	35
Elongation at break (traction) after 14 days at 23°C	2.8%	-	-	-	-	74%
Elongation at break (traction) after 16h at 40°C	2.3%	-	-	-	-	85%

Hardness : ISO 868

Traction : ISO 527-2

APPLICATION

1 Storage

In order to improve degassing, products should be stored at a temperature between 20 and 25°C. The colder the resin, the higher the viscosity, and the higher the viscosity the harder it is for the bubbles to escape from the resin.

This means that storage temperature should ideally always be above 20°C. However, after mixing, pouring and self degassing (approx. 1 h), the mold in which the resin has been poured maybe placed in a colder room during its hardening at temperatures below 20°C as this will help avoiding high exotherm temperature and therefore will allow to cast thicker layers.

2 Mixing

The mixing stage is the most important one. 99% of quality variations are the result of a poor mixing. It is highly recommended to follow the basic rules below :

- Our mixing ratios are expressed by weight: always use a scale and check that it is accurate – specially if battery operated.
- Start by pouring the hardener in the pre-mix container.
- Add the corresponding amount of WWA resin.
- Mix thoroughly but slowly not to include too many air bubbles.
- Once the mix is perfectly transparent and homogeneous, pour into second mixing container : This is called the **double potting technique** and it ensures that unmixed resin and hardener from the sides of the 1st mixing container are not used.
- Mix again and ensure perfect optical transparency before casting into the mould.

3 Casting

Once the mix is homogeneous, it is ready to be casted in the mould. Bubbles can appear during this stage, those bubbles will dissapear withing 15 minutes. None of the WWA range resin require mixing under vaccum except for the WWA HT where degassing the mix under vacuum is preferable.

4 Hardening

The thinner the resin film, the longer it will take to harden. On the contrary the thicker the cast is, the faster it will harden due to the mass effect.

For thick castings, it is recommended to work with a room temperature below 23°C, it will decrease risks of a high exotherm temperature.

5 Example : Manufacturing a river table

- **Selection of timber** : Select dry/seasoned wood as flat as possible. Do not leave bark as it would be a weak spot, remove it and sand the edges where the bark was.
- **Stabilization of the wood** : Wood is a porous material; some air bubbles could get out of the wood during hardening. To avoid this, it is recommended to coat the wood with a layer of epoxy. Fill cracks, knots, and any porous areas starting with what will be the bottom of the table, so that when you will place the bottom of the wood into the resin no air will be trapped. Like for any hardened epoxy, you will need to sand/deglaze before pouring more resin on it to ensure adhesion.

- **Casting techniques** : One of the many techniques possible once the wood stabilized consists in pouring a thin layer of resin in the mould (2 to 3 mm) to avoid any possible air pockets under the wood when placing it in the mould. Once the wood placed on the resin bed of 2/3 mm, clamp the wood in place so it won't float with non-stick spacers between the clamp and the wood. You can now pour the resin and flood the mould.

Another technique consists into placing the wood in the resin bed, pour the resin up to half to its final level and let cure overnight to b stage (resin has partially hardened, but is still stricky and you can put you nail into it) while holding the wood with clamps. The next day you can remove the clamps, the wood will be held in place and you can now do your final pour and flood the wood with the final desired resin thickness.

- **Casting thicknesses** : WWA/WWB4 is the perfect system to manufacture river tables, but as explained before thickness and room temperature are key points to determine the project feasibility.

***Example** : a 2m long x 30 cm wide x 4,5 cm thick casting in a 19mm melaminated wood mould in one shot is possible if the room temperature is between 18°C and 20°C, but the same casting at 23°C room temperature would see the resin heat up during hardening and cause yellowing, cracks and shrinkage. This means that just 4 or 5 °C temperature difference may be critical. **Play safe**: In case of doubt, cast in 2 times.*

- **Using resin translucent tints** : tints give great color aspects, but trying to obtain the same color at each mix is impossible. It is best to tint all the resin you plan onto using in one go. Nacre powder and metallic powders & flakes may also be used. Make sure all tints or fillers are epoxy compatible before using them.
- **Hardening** : The WWA+WWB4 system cures slowly and as a result, the temperature resistance increases slowly too. If you need to speed up the temperature resistance, once the resin has initially hardened, heat up at 40°C overnight.
- **Polishing** : All the WWA range sands and polishes well due to its excellent hardness. Best practice includes starting with 80 grit and wet sand from 400 grit onwards up to 2000 grit and then using any available polishing paste. The Resoltech WWI is approved for watches glass manufacturing and has similar resistances as sapphire.

Ask for technical advice : Resoltech's distributor networks consists of trained and experimented technicians Do not doubt in contacting them or our technical department for expert advice.

6 Effects/Causes/Solutions table

Effects	Causes	Solutions
The mix is not totally clear, some «filaments» are visible	The mix is not homogeneous enough	Stir untill the mix becomes totally clear
Some bubbles won't go up, there are stuck on mould sides or on included parts.	Bubbles are stuck because of the capillarity or because of the shape.	Soak all surfaces with mixed resin prior to casting
Resin hardened but there are still some «filaments» inside	Hardening is not 100% complete or the mix was not homogenous enough	Wait during 72h
The part went slightly yellow during hardening	A moderate exotherm oxydized the resin	Complete the hardening with a UV exposure, clearness should reappear
- Strong yellowing during hardening	Highly exotherm reaction	<ul style="list-style-type: none"> - Lower room temperature or product temperature - Decrease casting thickness - Use a slower system
- Surface is not flat (waves in surface)		
- Cracks		
- Important shrinkage		
Hardening did not occurred after 72h	Mixing ratio was incorrect or hardening is very slow due to low temperature	Check mixing ratio or increase room temperature, oven post curing is possible (not over 40°C)

PACKAGING

All WWA resins are available in kits of :

- 1kg (plastic jerrycan) + hardener
- 5kg (plastic jerrycan) + hardener
- 10kg (plastic jerrycan) + hardener
- 25kg (plastic drum) + hardener
- 225kg (steel drum) + hardener
- 1000kg (IBC) + hardener

TRANSPORT & STORAGE

Keep containers sealed and away from heat and cold preferably between 10°C and 30°C in a well ventilated area. Our products are guaranteed in their original packaging (check expiry date on the label).

HEALTH & SAFETY

Skin contact must be avoided by wearing protective nitrile gloves & overalls or other protective clothing.

Eye protection should be worn to avoid risk of resin, hardener, solvent or dust entering the eyes. If this occurs flush the eye with water for 15 minutes, holding the eyelid open, and seek medical attention.

Ensure adequate ventilation in work areas. Respiratory protection should be worn with ABEKP coded filters.

Resoltech issues full Material Safety Data Sheet for all hazardous products. Please ensure that you have the correct MSDS to hand for the materials you are using before commencing work.



The data provided in this document is the result of tests and is believed to be accurate. We do not accept any responsibility over the mishandling of these products and our liability is limited strictly to the value of the products we manufacture and supply.



249, Avenue Gaston Imbert
13790 ROUSSET
FRANCE

Tel. : +33 (0)4 42 95 01 95
Fax : +33 (0)4 42 95 01 98
export@resoltech.com